

# Quick Tips.

## ENVIROMETAL APPLICATION GUIDE

WolfGordon 

212 255 3300  
wolfgordon.com

# Scuffmaster®

Application Guide

Customer Service: 212 255 3300

## Getting Started

**REQUIRED MATERIALS:** To ensure a proper match, please follow the steps for either a brushed or rolled Envirometal finish.

- > **BRUSHED:** One roller set up with a 1/2 inch nap cover • One 3" high quality synthetic bristle brush • Painter's tape
- ROLLED:** One roller set up with a 1/2 inch nap cover • One roller set up with a specialty plush fabric roller cover (Wooster Polar Bear™ for example) • 4 inch roller (A Whizz™ for example) for cutting in • Roller tray • Painter's tape.

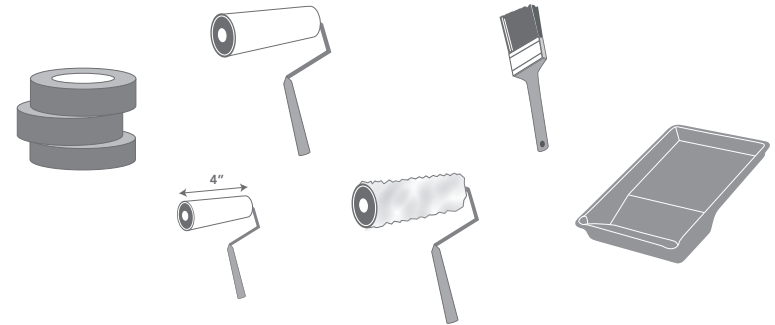

## Preparation

EnviroMetal is a highly reflective finish that will telegraph any substrate flaws. The substrate must be very smooth. Fill in all visible dings and scratches. Mask off the surface to be painted, this will reduce any "picture framing" caused by variations between brushing and rolling.

- > **PRIME: MUST USE TINTED PRIMER!** On new sheetrock use Scuffmaster Tinted Prebase Primer/Sealer. For painting over glossy surfaces use Scuffmaster Tinted Bonding Primer.
- IMPORTANT: TEST BEFORE PROCEEDING!** Prepare a sample wall, test or mock up (not to exceed one gallon) under job conditions before proceeding with the actual application to determine the suitability of appearance. Once materials are applied, they are considered to be accepted and MCT will assume no further responsibility.

## Application / Brushed

**NOTE:** An EnviroMetal Brushed finish is achieved in TWO COATS, each coat consisting of first rolling the EnviroMetal, then brushing the pattern.

**BRUSH BOTH COATS!** Simply rolling the first coat then rolling and brushing the second coat will leave lap marks and stippling that will be visible through the finish.

ENTIRE WALL

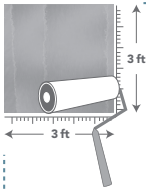

**1. START BY ROLLING THE FINISH**

- Starting with the top left of the wall, roll a 3' x 3' square using the 1/2" nap roller.

DO NOT ATTEMPT TO ROLL AN AREA LARGER THAN 3' X 3'! This will result in the paint drying too fast causing it to ball up when it is brushed!

ENTIRE WALL



**2. BRUSH THE FINISH**

- IMPORTANT! BE SURE TO START THIS PASS WHILE THE PAINT IS STILL WET!** Brush as close to the masking as possible to avoid any "picture framing."

While the paint is still wet, use the 3" synthetic brush to make quick, random criss-cross strokes. Feather out the edges. This helps blend the sections together.

ENTIRE WALL

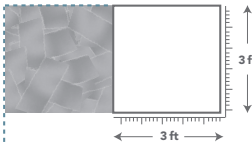

**3. MOVE TO NEXT 3' x 3' SECTION**

- Move to the adjoining section, repeat steps 1 & 2. Leave a narrow gap approximately 1" between each section. This will prevent the build up of paint. Repeat this process until the entire surface is covered.

**BLENDING:** Be sure adjacent area is dry before blending.

**REPEAT THESE STEPS FOR THE SECOND COAT**

## Application / Rolled

**NOTE:** An EnviroMetal Rolled finish is achieved in TWO COATS, each coat consisting of first rolling the EnviroMetal, then backrolling the finish.

**CUT-INS MUST BE BACK ROLLED TO ELIMINATE BRUSH STROKES!**

ENTIRE WALL

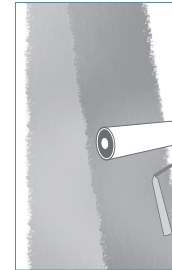

**1. APPLY WITH THE 1/2" NAP ROLLER**

- First, cut in with a 3" brush and back roll with the Whizz™ roller to eliminate brush strokes.

Using the 1/2" nap roller cover, roll the paint floor to ceiling over 3 linear feet.

ENTIRE WALL

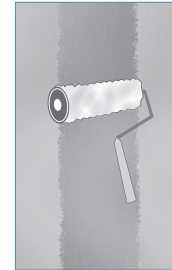

**2. BACK ROLL WITH THE WOOSTER POLAR BEAR™**

- Switch to the Wooster Polar Bear™ set up. Lightly roll just past the edge of section to avoid lapping.

ENTIRE WALL



**3. MOVE TO NEXT 3 LINEAR FOOT SECTION AND REPEAT STEPS 1 & 2**

- Keep repeating this process until the entire surface is covered.

**REPEAT THESE STEPS FOR THE SECOND COAT**

## Troubleshooting

**IMPORTANT:** Call our support line at 212 255 3300 if you are unclear on any step of the application.

EnviroMetal is a highly reflective finish that will telegraph any substrate flaws. Be sure all surfaces are prepared to an acceptable level of smoothness.

### Rolled Finish Has Visible Striping in it:

**Cause 1:** Over rolled with the Polar Bear™ set up

**Cause 2:** Not enough paint on roller or working in too large an area

**Solution 1:** Lightly roll over the area only once or twice.

**Solution 2:** Coat the entire roller, but not so much that it drips excessively, and work in smaller sections.

### Rolled Finish Has Visible Brush Strokes In It:

**Cause:** Didn't roll as close to the masking as possible

**Solution:** Use the 4" Whizz™ roller.

### Brushed Finish Has Basketweave/Obvious Pattern:

**Cause:** Deliberate brush strokes

**Solution:** Apply random, criss-cross strokes with paint to break up the pattern.

### Brushed Finish Has Visible Texture/stipple:

**Cause:** Simply rolled first coat – Did not brush

**Solution:** Sand as smooth as possible to remove stipple then reapply.